

➤ Linen (Exodus 26:1)

√ Pictures Jesus in His heavenly glory and perfect righteousness
(1 Cor 1:30; Eph 1:20-22; 1 Pet 1:21)

The Door

 (Exodus 26:36-37)

- Pictures Jesus as the door to fellowship with God and abundant life in Him (John 10:9-10)

Thinking it Through...

How has your understanding of the tabernacle so far, enhanced your understanding appreciation of what Jesus has done for you? Explain.

Will that prompt you to change in an area of your response to God this week? In what way or ways?

The tabernacle and its furnishing all point to Jesus Christ.

The layout of the tabernacle reveals that salvation is God''s plan

- It begins with God and moves toward man
- It reveals God's prescribed way to approach Him

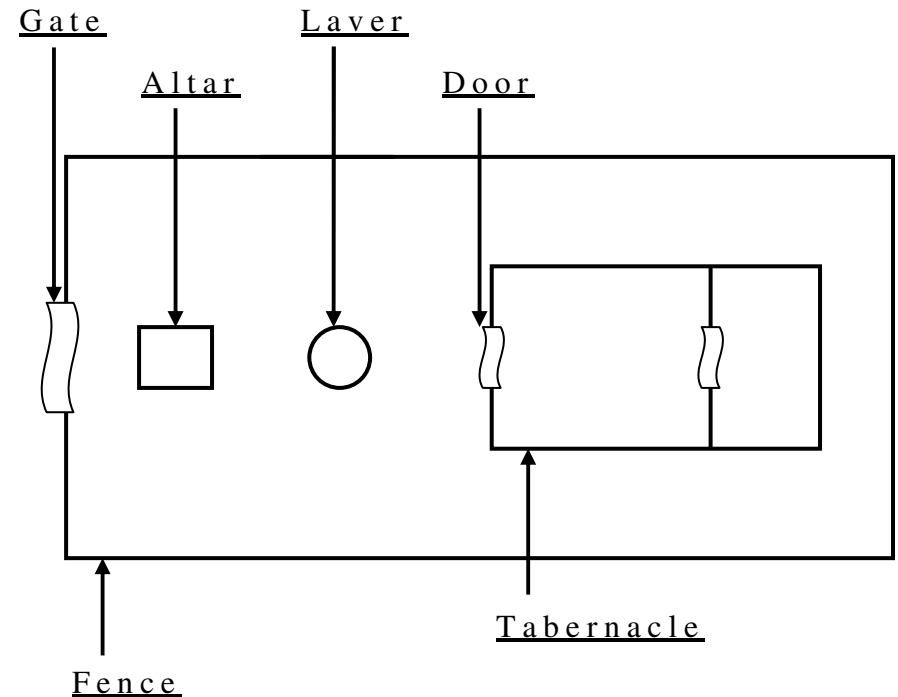

(continued on inside)

The Fence (Exodus 27:9-19; Isa 24:16; 64:6; 1 John 2:1; 2 Cor 5:21; Rom 3:11-12)

- Pictures the righteousness of God

The Gate

(Exodus 27:16; John 10:7-9; Matt 7:13-14; Phil 2:5-11)

- There was only ONE way to enter
(Lev 17:3-4; John 14:6; Acts 4:12)
- The entrance points to the character of Christ
 - Purple = speaks of Christ as King (*Matthew*)
 - Scarlet = speaks of Christ's sacrifice (*Mark*)
 - White = speaks of Christ's perfection (*Luke*)
 - Blue = Christ's heavenly character - deity (*John*)

The Altar (Exodus 27:1-8)

- The bronze altar speaks of Christ as our sacrifice
(John 3:16; Heb 9:26; Heb 10:10-14)

The Basin – Laver (Exodus 30:17-21)

- The bronze basin speaks of Jesus as the one who cleanses us from sin (Psalm 119:9; John 15:3; 17:7; Eph 5:26; 2 Tim 3:16-17; 1 John 1:8-9)

The Tabernacle (Exodus 26:1-36)

• **The Tent:**

Had four coverings (going from the outside to the inside)...

- Badger/Porpoise skin
(Exodus 26:14; Isa 53:2,3; 1 Cor 2:14)
- √ Pictures the humanity of Jesus
(John 1:14; 6:42; Matt 13:55-57)
- Ram's skins (Exodus 26:14)
- √ Pictures Jesus as the substitute for sinners
(John 1:29; Rom 5:8)
- Goats Hair (Exodus 26:7-13; Lev 16:15-22)
- √ Pictures Jesus as our sin-bearer
(Isa 53:6; Heb 9:28; 2 Cor 5:21)

(continued on back)